

High-Sensitivity Dilatometer for Quality-Control Use¹

G. S. Tomer,² G. L. Schlegel,² and P. S. Gaal²

A simple-to-operate dilatometer, intended for rapid quality-control testing of low-expansion materials in a single temperature interval, is described. The instrument employs a thermoelectric heat/cool element to supply the thermal environment for the sample and a high-sensitivity linear variable differential transformer (LVDT) for displacement measurement. The mechanical configuration is made so as to eliminate the need for quartz correction and to provide a 4:1 mechanical advantage to the displacement signal for improved accuracy. Operating between 0 and 100°C, the machine proved to give consistently good results with materials having expansion coefficients as low as $0.5 \times 10^{-6} \text{ }^\circ\text{C}^{-1}$. Representative data on some carbonaceous materials and fused silica (quartz) are given.

KEY WORDS: composites; dilatometer; thermal expansion.

1. INTRODUCTION

It is a frequent occurrence in industry that a seemingly simple-to-measure property is chosen as a criterion for acceptance or rejection of large production lots of materials. Often, the people who specify this item have no detailed knowledge of the measuring method, the difficulties associated with it, or even the general procedure one follows in determining this property. Severely compounding the situation is the existence of archaic practices that have little to do with the ultimate use of the material and its true performance. A good example is how some carbon and graphite products are often characterized for their thermal expansion behavior. Since process steam and ice baths were readily available in plants, it became customary to use a simple tube-type dilatometer accommodating a very long sample and determine the coefficient by sequentially dunking it

¹ Paper presented at the Ninth International Thermal Expansion Symposium, December 8–10, 1986, Pittsburgh, Pennsylvania, U.S.A.

² Anter Laboratories, Inc., 1700 Universal Road, Pittsburgh, Pennsylvania 15235-3998, U.S.A.

into these two baths. Unquestionably, it is a simple, ingenious, and cheap way of getting data in a hurry and right on the production floor. How this narrow-range data predict performance several thousand degrees higher is another matter. The complications have lately become enormous, since very low-expansion carbon and carbon/carbon composites are still being measured over this narrow temperature range. Sample size has shrunk due to cost and geometrical availability. With the resultant minute expansion, the old, reliable dial gauge has reached its limit. The obvious alternative of using more sophisticated conventionally instrumented quartz tube dilatometers also has its drawbacks. Devices that are developed for a much broader temperature range (usually RT to 1000°C) are also made a lot more flexible than a restricted check would need, and consequently, costs are difficult to justify. Operation of such instruments is geared to laboratory personnel and is reasonably complicated. Even after overcoming the first two hurdles, one faces the most important limitation—the very nature of a quartz tube dilatometer. It is well known that such a device always measures the difference in expansion between the quartz tube itself and the sample. Therefore, a correction must always be added to the measured values to compensate for this. For most materials, the magnitude of this correction is small compared to the sample's own expansion. However, for a low-expansion material, the correction may even be larger than the measured value itself, resulting in a scatter that can become as high as 40–50%. Further compounding this problem is the generally poor performance of broad-range dilatometers in the bottom 10% of their temperature range.

There are numerous absolute methods that can function in the near-ambient range, some of which are highly accurate and extremely sensitive. Interferometers are excellent but very difficult to operate; twin-telescopes (and optical methods in general) are widely used but require a great deal of skill and a clean, well-controlled laboratory environment. Interesting compromises can be found in works of earlier investigators, such as the one described by Hidnert and Souder [1] and Liebfried [2], which still rely on very large specimens and fluid baths. The quest for devising methods that do not rely on tube/push-rod displacement transmission is not new. Optical levels have been used successfully, but the motion sensing was always a difficult problem. It was in this frame of reference that the new work was to develop a device that can measure materials with a coefficient of about $0.5 \times 10^{-6} \text{ } ^\circ\text{C}^{-1}$, using a comparatively small sample (3 to 4 in.), and be totally operable in an automatic fashion, as a quality-control tool.

2. DESCRIPTION

The design principles are shown in Fig. 1. The sample is completely surrounded by an aluminum block furnace (A) which is coupled to a thermoelectric heat/cool element. The operating range of this device is about -10°C on the low end and 110°C on the high. Contacting each end of the sample is a long quartz rod (B) suspended from another massive quartz bar (C) above and parallel with the sample (D). First, class 7 super-precision ball bearings were tried for the pivot, but due to inadequate lateral stiffness, they proved unsatisfactory and were later replaced with leaf springs. Mounded on the lower end of each vertical quartz rod is another quartz piece (E, F), again parallel with the sample (D). Held between these two is the high-sensitivity displacement transducer (G). At first, a narrow-range DCDT was used because it offered a 99.9% linearity over 10 mil, but later it was replaced with an ordinary AC device. This linear variable differential transformer (LVDT) had much poorer specifications but in reality it performed equally well. The latter choice allowed a much broader lateral clearance between the core and the armature, making mechanical adjustments easier. To ensure that the contact tips on the vertical arms firmly track the sample, counterweights were first added close to the pivot point but were later replaced with adjustable force springs in line with the

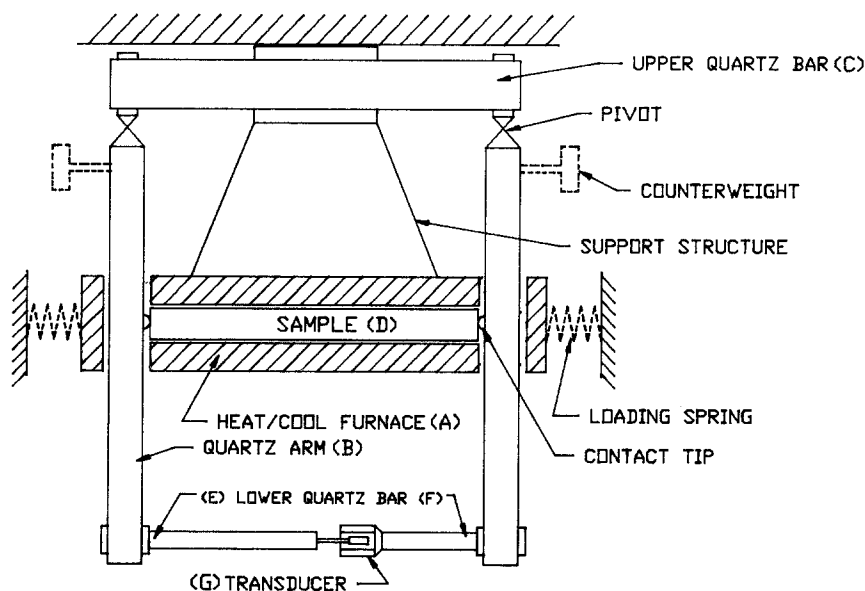

Fig. 1. Schematic representation of the dilatometer.

sample. This was to preclude any possibility of bending moments developing along the arm which could contribute to the measured signal. Figure 2 shows the assembled instrument with its cover removed.

The excitation/demodulation for the transducer is accomplished with a single integrated circuit chip thermostated for stability. In the initial configuration, the electronics consisted of a programmable controller scheme based on sequentially executed steps stored in an EPROM (erasable

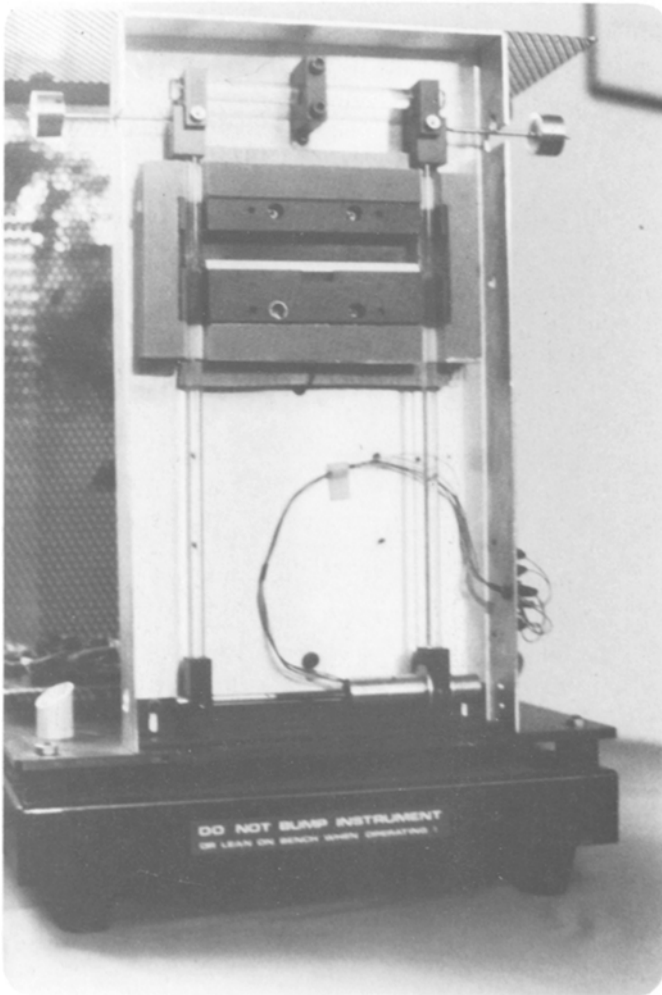

Fig. 2. The Unitherm dilatometer.

programmable read only memory), with no decision-making capability at all. The cycle was initiated with a single push-button, after which the temperature is controlled to 0°C for a present number of steps (time intervals). At the end, the LVDT signal was bucked out automatically to zero, and the DAC (digital-to-analog converter) supplying the bucking voltage was frozen. The next segment was heating up to 100°C again for a present length of time, after which the DVM (digital voltmeter) display was disabled, thereby retaining the last reading. The scaling was such that the display showed the coefficient directly for this temperature range. A forced cooling to RT followed to hasten the completion of the test, at which point all the operator had to do was note the display reading and go on with the next test.

3. DISCUSSION

In extensive use, it was found that the speed of the thermoelectric heat/cool module heavily relied on the room temperature into which the heat rejection is done; thus, the device was slower in a warm room than in a cool one. Setting the time long enough to accommodate the hot summer days robbed precious cycle time in a production environment where tests are run continuously. For this reason, the control scheme was changed to include a simple computer that could make certain limited logical decisions and store the data as well. With this configuration, the operator's burden is not increased, since the single screen display contains all of the step-by-step instructions one may need. With this, the calculated and displayed coefficient was for the exact temperature excursion the sample had experienced. Instead of presetting times for heating, equilibration, etc., the equilibration process was monitored and compared against certain criteria on a continuous basis. As soon as the specimen was within 0.5°C of the desired temperature and its temperature had not change more than 0.2°C in any continuous 5-min interval, while its expansion had not changed more than a certain amount, equilibrium was declared, and the program went on to the next segment.

In examining some of the geometrical (configurational) and mechanical sources of error, it is obvious that the sample length is compared to the length of these quartz pieces parallel with it. These quartz pieces, being made of a very low-expansion material, will change very little as long as the temperature of the environment changes little during the duration of a test. Therefore, the speeding up of the operation tends to improve accuracy further. Since the vertical arms are pivoted, there is a minute difference between the lateral movement of the sample and the arc the contact point follows. Calculations show that this geometrical deviation

causes differences that are several magnitudes lower than the measured value, even for a quartz sample. Bending of the vertical arm was found to contribute more to degradation of data than any other source of error previously mentioned. For this reason, the counterweights which created a bending moment were replaced with springs that acted in line with the control point. The effect of allowing the sample to float by supporting it on linear ball bushings was examined, and it was found to make no difference. For simplicity of operation, the most recent configuration restrains the specimen at its center.

The system was verified with NBS standard reference materials, fused silica and borosilicate glass. These showed a 3% accuracy for the range and a $\pm 2\%$ repeatability in general. A great number of tests on generic quartz samples had shown to result in a slightly poorer repeatability. Several grades of extruded carbon (made of needle coke) were also tested (as the ultimate use of the machine was with this class of materials) and it was found that differentiating two materials with coefficients of 0.35×10^{-6} and $0.42 \times 10^{-6} \text{ } ^\circ\text{C}^{-1}$ was readily accomplished.

In summary, the system described combines elements of absolute expansion measurement techniques and automated process control to result in an easy-to-operate, narrow-range, high-sensitivity quality-control tool.

REFERENCES

1. P. Hidnert and W. Souder, *Thermal Expansion of Solids*, NBS Circular 486 (U.S. Government Printing Office, Washington, D.C., 1950), p. 3.
2. G. Liebfried, *Z. Phys.* **127**:580 (1950).